

6

5

4

3

2

1

TYPE	OUTPUT		POLE	TIME RATING	VOLTAGE V	Hz	SYN. SPEED R.P.M
	HP.	kW.					
AEHCED	250	186.4	4	CONT	2300/4000	60	1800

TOTALLY ENCLOSED FAN-COOLED VERTICAL SOLID SHAFT TYPE, SQUIRREL CAGE ROTOR

NOTE:

1. DIMENSIONS IN INCH
2. FRAME NO. 449VP
3. F CLASS INSULATION, S.F.: 1.15
4. FOR DIRECT COUPLING.
5. BEARING SIZE:  
UPPER BEARING: 7326B (UNINSULATED)  
LOWER BEARING: 6318C3 (UNINSULATED)
6. LUBRICATION:  
UPPER BEARING USE OIL.  
OIL VISCOSITY: ISO VG68 [300SSU AT 100°F]  
OIL QUANTITY: 1.8 GAL.  
LOWER BEARING USE GREASE. (MOBIL POLYREX EM)
7. ROTATION: COUNTER-CLOCKWISE [VIEW FROM TOP].
8. WITH NON-REVERSE RATCHET MECHANISM.
9. APPROXIMATE WEIGHT: 3010
10. DOWNTHRUST: 10,000 LBS (L10-8800HRS)
11. REED FREQUENCY: 36 HZ
12. SPACE HEATER RATED AT 120 VOLT, SINGLE PHASE, 109 WATTS, LEADS TERMINATE IN MAIN LEAD BOX.

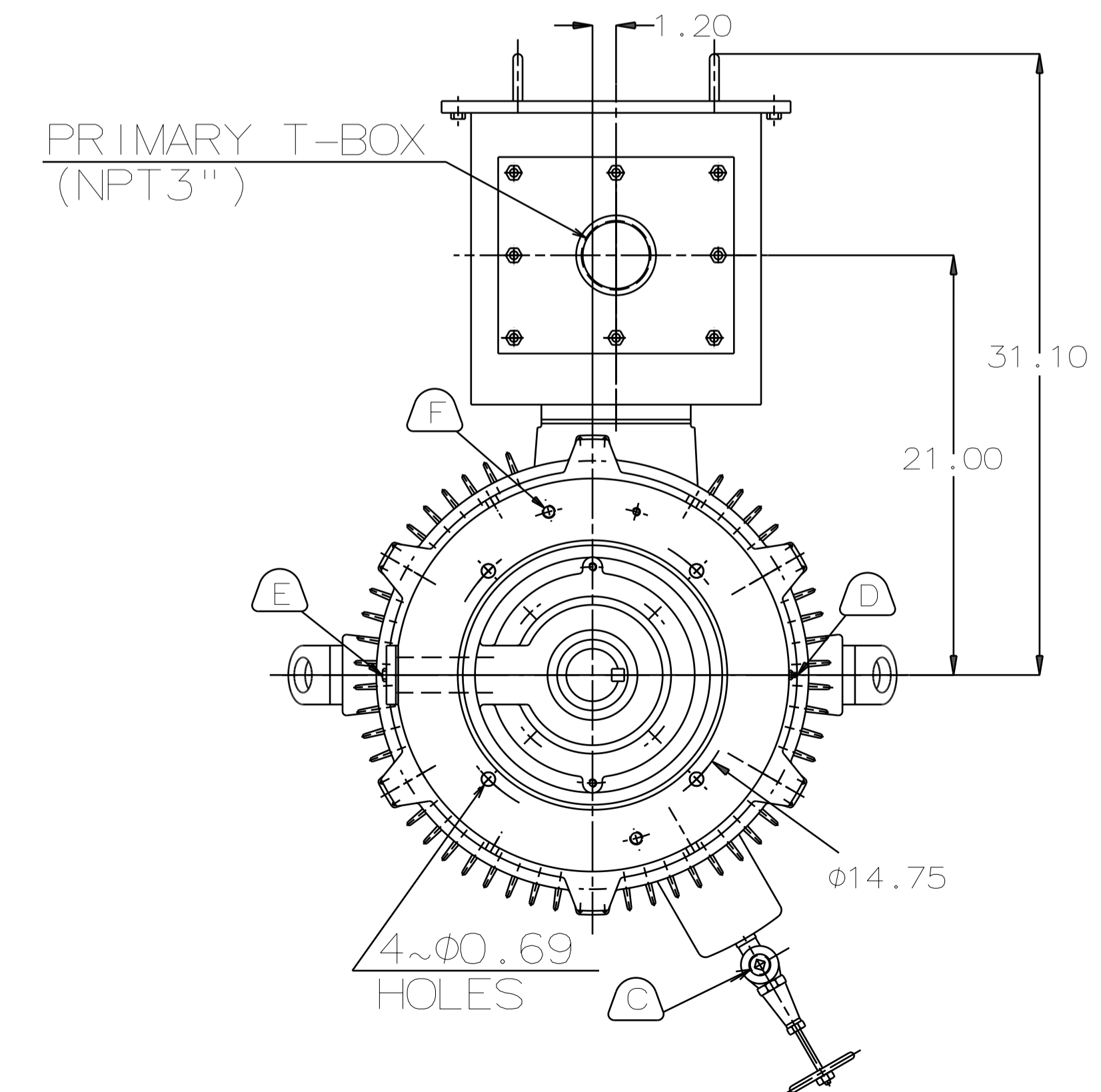
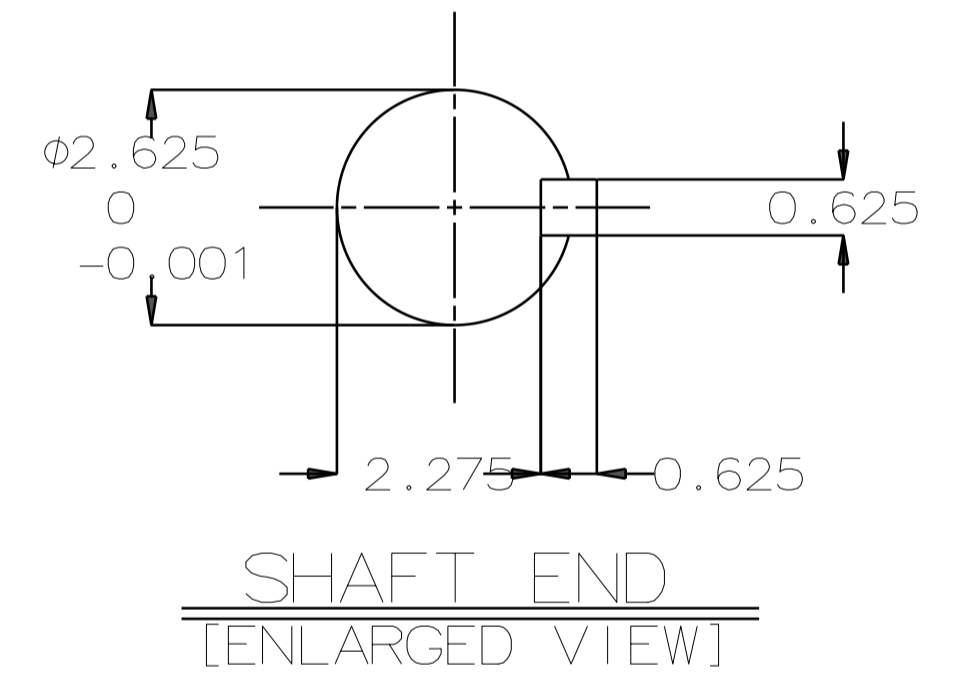
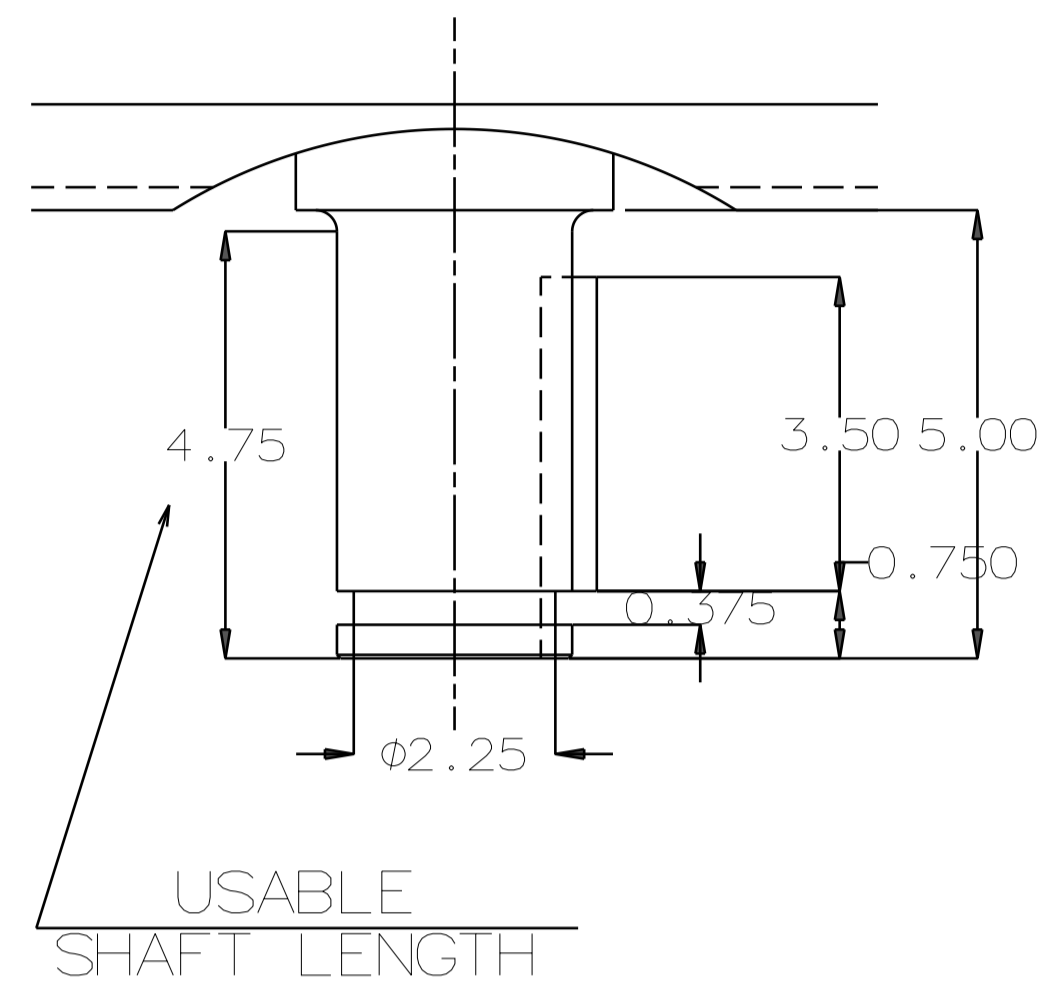
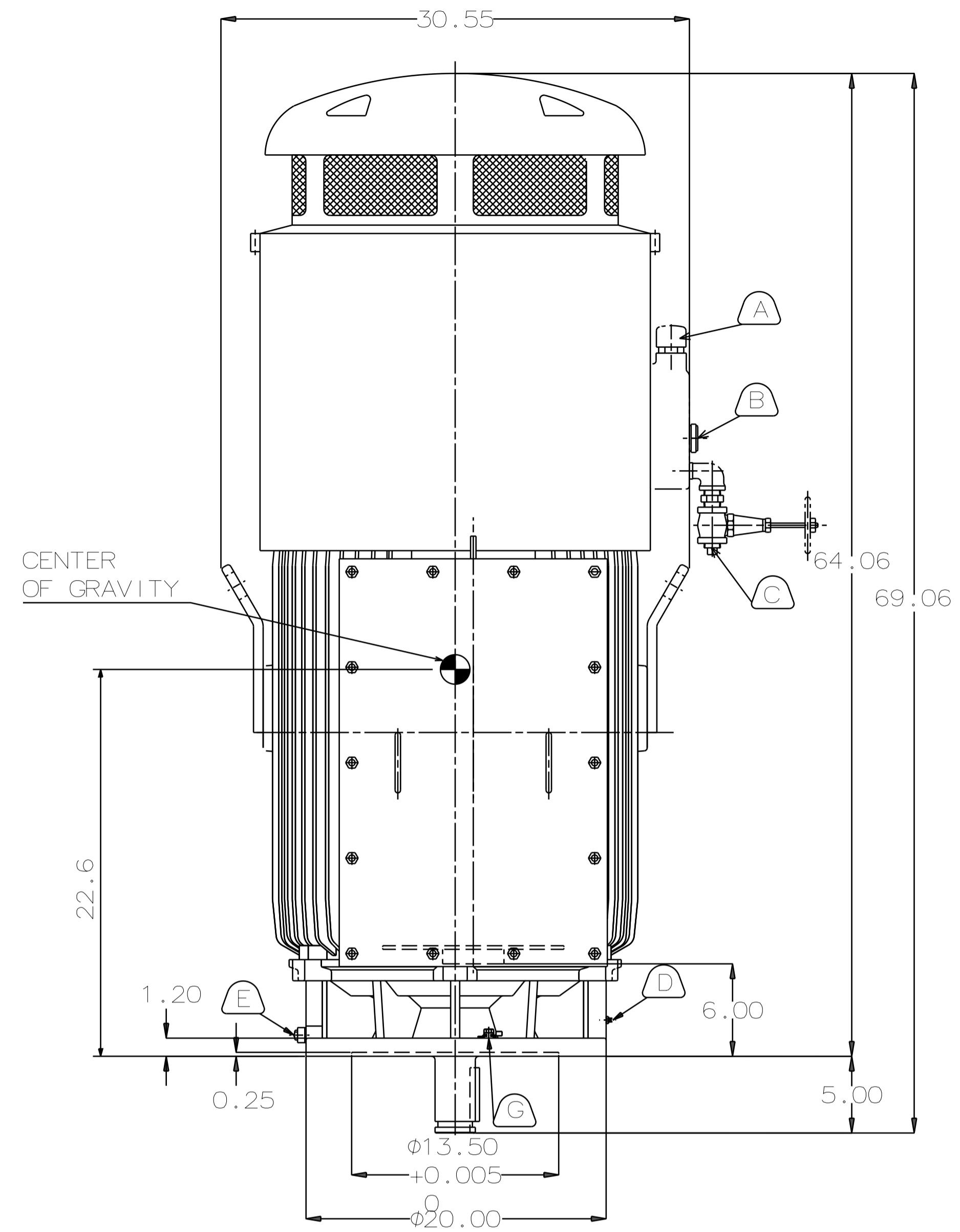

- A OIL FILLER [UPPER BEARING]
- B OIL GAUGE [UPPER BEARING]
- C OIL DRAIN [UPPER BEARING]
- D GREASE INLET [LOWER BEARING]
- E GREASE DISCHARGER [LOWER BEARING]
- F 2~M16 VERTICAL JACKING HOLES 180° APART IN MOTOR BASE.
- G M10 TAPPED HOLE IN MOTOR BASE WITH GROUNDING TERMINAL [R38-10] & BOLT LOCATED AS SHOWN.

DATE	DEC 08 2016	OUTLINE DIMENSIONS	
	VSKTP2504	3-PHASE INDUCTION MOTOR	
DWG NO.	4B040L418	REV:00	

DWN.	Y. YANG	MAY. 23. 2015
CHKD.	R. LEE	MAY. 23. 2015
APPD.	C. LIU	MAY. 23. 2015



6

5

4

3

2

1